

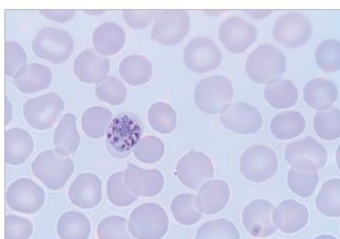

ZEISS Primo Star

The High Performance Upright Light Microscope for Labs and Education



Plasmodium malariae, daisy-head stage, courtesy of Andrea Michelsen, Central Laboratory of Ortenau Klinikum, Lahr-Ettenheim, Germany

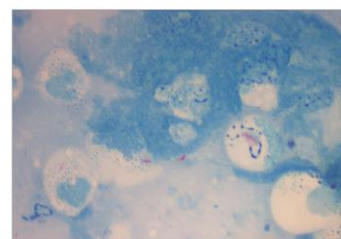

Conventional Ziehl-Neelsen staining of Mycobacterium tuberculosis, courtesy of Dr. med. Harald Hoffmann, WHO - Supranationales Referenzlabor IML, Gauting, Germany

Primo Star has been developed with long-term use and great durability in mind. It incorporates all of ZEISS's experience in optical microscopy adapted to the most sophisticated environmental conditions in classroom settings and laboratory work.

Together with its many practical accessories, Primo Star can be used for education, in the laboratory, doctors' practice and in the field.

Connect several microscopes in your classroom to HD monitors or projectors with the internal HD streaming camera in conjunction with the iPad Imaging App Labscope from ZEISS. Make teaching easier by sharing your Primo Star images or videos with your students, helping them to learn quickly and effortlessly.

Highlights

- Easy to operate
- Robust and durable
- Quality optics from ZEISS
- Excellent price/performance ratio
- Modular illumination concept
- 5-step LED-display intensity indicator panel on both sides of stand
- All functions can be learned quickly
- Suitable for education and routine work in all areas of microscopy.
- Optional internal HD camera and iPad App, Labscope.

Healthcare & Clinical

Using Primo Star, it is possible to use all the applications and contrasting methods that are relevant to healthcare:

- Stained tissue sections in medicine
- Unstained cells in phase contrast in medicine and biology
- Examination and analysis of germs and bacteria in the lab and during field work

The Digital Classroom

Primo Star, with internal HD camera and iPad App Labscope, connects all the microscopes in your classroom. See an overview of all the images from the connected systems, then choose single images or videos and share them with other students.



تهران، خیابان مطهری، خیابان فجر، پلاک 38





ZEISS Primo Star

The High Performance Upright Light Microscope for Labs and Education

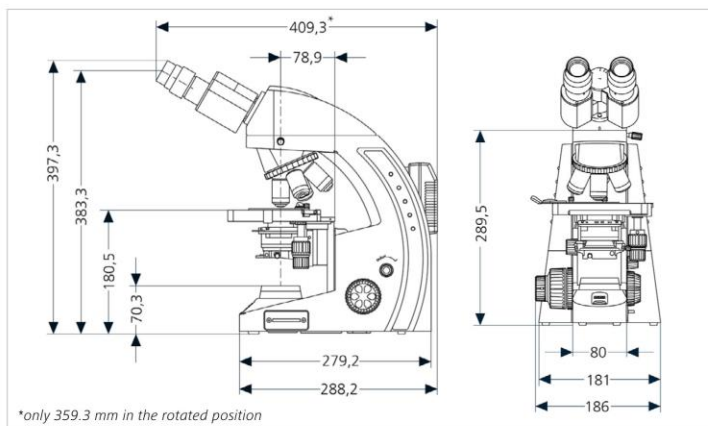

*only 359.3 mm in the rotated position

Technical Data

Optical system	Color-corrected infinity optics
Parfocal distance	45 mm
Tube length	180 mm
Two stand variants	Full-Koehler and Fixed-Koehler
Magnifications	40x to 1000x for visual observation, 4x to 100x for camera observation
Eyepiece tubes	Swiveling Siedentopf tube with upper and lower position, upper position offers approx. 40 mm extra viewing height, Adjustable interpupillary distance: 48 mm-75 mm, Tube can be rotated 360°, 30° viewing angle (ergonomic angle), Binocular tube and binocular phototube, 50%:50% (vis:doc), Several photo adapters available for phototube
Eyepieces	WF 10x/18 Br. foc., WF 10x/20 Br. foc., Eyepiece pointer can be retrofitted
Nosepiece	4x, inclined backwards, 4x, reversed
Condenser	Abbe condenser 0.9/1.25 Holder for phase contrast and darkfield sliders Two variants for fields of view 18 mm (Fixed-Koehler) and 20 mm (Full-Koehler)
Illumination	Modular illumination concept with drawer, HAL (30 W/6 V), LED (3 W/6 V, roughly corresponding to brightness of 20 W HAL)
Stage	Stages available with either right-hand or left-hand operation
Area of stage	w x d: 140 mm x 135 mm
Travel range	w x d: 75 mm x 30 mm
Z-drives	Fine drive: 0.3 mm/rot., Coarse drive: 4 mm/rot., Total travel range: 15 mm

Objectives

Plan-Achromat 4x/0.1 - WD: 6.50 mm
Plan-Achromat 10x/0.25 - WD: 4.39 mm
Plan-Achromat 40x/0.65 - WD: 0.48 mm
Plan-Achromat 100x/1.25 - WD: 0.13 mm
Plan-Achromat 40x/0.65 Ph2 - WD: 0.48 mm

Special Features:

- Carrying handle integrated in stand
- Intensity indicator panels in a 5-step LED-display on both sides of stand
- All optical components in Primo Star are anti-fungus treated.

Accessories:

- Eyepiece pointer
- Phase contrast equipment (Plan-Achromat 40x/0.65 Ph2 + Ph2 slider)
- Darkfield equipment (DF slider 0.65)
- LED-fluorescence accessory kit available
- Integrated HD camera and Labscope iPad app.



Norms and Standards Met:

CE, CSA, UL, ICC, ISO 9001, IvD



تهران، خیابان مطهری، خدایان فجر، پلاک 38

021-88832100
021-88321727
021-88321728
www.abzarteb.com
abzar.teb



microscopy@zeiss.com
www.zeiss.com/primostar